Catalog

2019 - 2020

NO BOUNDARIES



www.buzzi.space

About BuzziSpace

BuzziSpace creates solutions for happy and healthy workspaces around the world. With a mission to improve well-being through human centric design, the Belgian design brand provides original acoustic solutions, lighting and furnishings to meet the needs of the modern workplace.

It started with acoustics. From there, the mission grew. Driven by an unbounded passion for solving modern design challenges, BuzziSpace continuously reimagines furnishings to be more functional

and fun. The brand's in-house studio collaborates with talented designers to provide new ways of working and living—comfortably, collaboratively and sustainably.

Established in 2007, BuzziSpace has grown into an award-winning acoustics leader. The Antwerp-based company has established an international presence with showrooms in Antwerp, New York, Chicago, London and Aachen, and its own manufacturing facilities in Bladel (NL) and High Point (US).



Our JOURNEY

FOUNDED IN ANTWERP BELGIUM

2007

SAS ADRIAENSSENS
DESIGNED THE FIRST PRODUCTS FOR BUZZISPACE

OVAM Ecodesign Award PRO 2009
(BuzziScreen, BuzziZone and BuzziBoard)

2008

OUR FIRST INTERNATIONAL FAIRS

2009

2010

ALAIN GILLES
STARTED DESIGNING FOR BUZZISPACE

THE FIRST YEAR WE ATTENDED ORGATEC (DE)

Henry Van de Velde Award 2011
(company)

2013

RELOCATION BUZZICAMPUS
KONTICH (BELGIUM) WITH THE BUZZICHICKENS

2012

OPENING LONDON SHOWROOM
FIRST TIME EXHIBITING AT **NEOCON** (US)

Designer of the Year 2012
(Alain Gilles)

2014

We welcomed some BuzziBees at the BuzziCampus, because treating them well is very important to our planet

2014

The year we started manufacturing in the US (High Point)

- Contract Best of NeoCon 2016** (BuzziBalance)
- Interior Design HiP Award 2016** (BuzziBlinds)
- #MetropolisLikes Award 2016** (BuzziJungle)

2017

- Interior Design HiP Awards** (BuzziMood)
- Hospitality Design Awards Winner** (BuzziPleat LED & BuzziHat)
- Interior Design Best of Year Award** (BuzziSpark)
- Contract Best of NeoCon Silver Award** (BuzziHat)
- Archiproducts Design Award Winner** (BuzziBracks)

2015

- Interior Design HiP Award 2015**
- Contract Best of NeoCon 2015** (BuzziFalls)
- Architectural Records Products of the Year 2015** (BuzziHub Open)

2016

WE CELEBRATED OUR 10TH ANNIVERSARY

10

TEN YEARS OF HAPPINESS AT WORK

- Interior Design HiP Award 2017** (Manufacturer of the Year)
- Contract / IIDA Best Showroom Design** (NeoCon)
- Interior Design HiP Award 2017** (BuzziPleat)
- Best of NeoCon Gold Award** (BuzziPleat)

2018

2019

Local Manufacturing

At heart, we're all makers. We're born that way. Each one of us possesses the skills to create things that will amaze and surprise others, even ourselves. It happens daily at our local manufacturing facilities in Bladel (NL) and High Point (US)—fueled by a shared desire to make durable and high-quality furnishings, both facilities bring out that extra sparkle in every BuzziSpace product that sets the brand apart from the competition.



Local Manufacturing in Bladel & High Point

Furniture-making is a tradition that goes back many years in both Bladel and High Point. While the story behind each facility is unique, a common thread unites them: the ability to create quality products of the highest standards. In fact, the rich legacy of manufacturing furniture in both areas is a major reason why BuzziSpace chose Bladel and High Point for its manufacturing locations.

Just across the border of Belgium in the Netherlands, you will find our manufacturing facility in Bladel. From the outside, it might look like any other production facility, but on the inside, it is anything but. Welcome to a world of imagination and innovation, a world where ideas are turned into reality - the world of BuzziSpace.

The facility in Bladel houses more than 80 employees across several departments, with more than 100 years of combined experience in foam cutting, upholstery and stitching. A handful of its current workforce was brought on from the last company

to occupy the space, a manufacturer of caravan cushions, consequently bringing with them a strong level of expertise in upholstery and foam-work, which has been key to creating several BuzziSpace products.

Despite having an extensive skillset, employees do sometimes face challenges. The truth is, the process of making caravan cushions differs greatly from that of making a BuzziSpace product - the work is more rigorous and complex, and requires a much keener eye for detail.

For example, making a product like BuzziCube 3D involves a particularly complex lamination process. Expertise is required to find the right balance between pressure, temperature and glue, to seamlessly fasten fabric to the 3D cut foam. Every time a new fabric is introduced, our production team has to reevaluate the formula from scratch, so the team is constantly innovating to meet new challenges.



Across the Atlantic, we also work hard to maintain our position as an industry front-runner. Establishing a second manufacturing facility in High Point, North Carolina, has been critical to our success.

Every day, 35 employees strive to deliver products of the highest quality at this location, which used to be an old cotton mill before it was transformed into a BuzziSpace manufacturing facility.

With a rich history of furniture-making and a skilled local labor force, High Point was the ideal location for us to establish production in America.

At BuzziSpace, craftsmanship is crucial to guarantee high-quality finished products. In several departments, much of the work is still done by hand, requiring special techniques to achieve the desired result. For instance, lacing and upholstery are some of the departments in which the work necessitates a steady hand and eye for detail. Here, the work is both an art and a skill.

Every year, thousands of meters of fabrics and cubic meters of foam are used to produce BuzziSpace solutions. It's inevitable to avoid any waste materials. With sustainability being one of BuzziSpace's founding pillars, both facilities have implemented recycle management of core materials such as foam, cardboard and fabric.

In Bladel, for instance, foam recycling has proven to be a great success in resourcing old materials and eliminating excess waste.

In High Point, sustainable practices are primarily guided by LEED (Leadership in Energy and Environmental Design), a green building certification program.

Despite the distance between our two facilities and some differences, both locations share an important place in BuzziSpace's existence: a shared passion for making products that will solve the modern design challenges of today—and beyond.

“Lacing and upholstery are some of the departments in which the work necessitates a steady hand and eye for detail. Here, the work is both an art and a skill.”



Meet our Designers

BuzziSpace has always given opportunities to both upcoming and established designers to develop products and ideas that match the DNA of BuzziSpace. These designs are often ahead of their time and each tells a unique story. They do not only look good but they also meet a particular need.

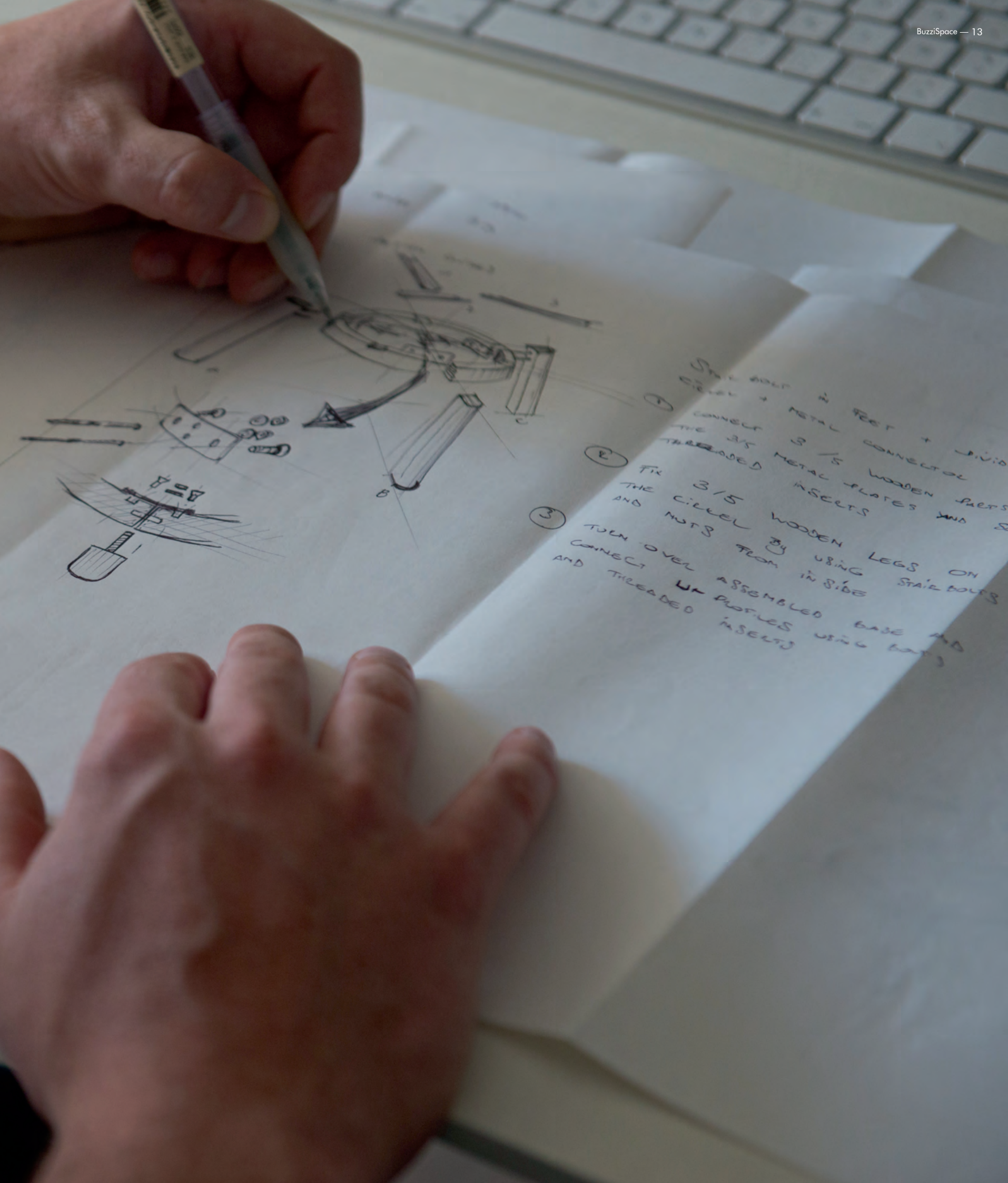



- ### AWARDS
- 🏆 Design Brussels Awards 2007 (Best Belgian Product)
 - 🏆 L'esprit Marie Claire Maison 2008 (Maison & Objet Paris)
 - 🏆 Design at Work 2008 (Interieur Foundation)
 - 🏆 Henry Van de Velde Label 2009 (BuzziBoard)
 - 🏆 OVAM Ecodesign Award PRO 2009 (BuzziScreen, BuzziZone and BuzziBoard)
 - 🏆 Contract Best of NeoCon 2015 (BuzziFalls - Gold Award Winner)
 - 🏆 Interior Design HiP Award 2015 (BuzziFalls - Winner)
 - 🏆 Architizer A+ Award 2016 (BuzziFalls - Popular Choice)

Sas Adriaenssens



I don't design with the 'new way of working' in mind, because I believe that people work and live how they want to. It's my role as a designer to listen to their needs and try to give them a personalized solution.

Sas Adriaenssens obtained a master's degree in graphic design and illustration and after several years in marketing, naturally moved into the world of interior and product design. After many years of experience in companies of all shapes and sizes, she went freelance in order to create her own cocktail of creativity and practical organisation. She prefers to describe herself as a 'creative problem-solver with a compulsive aesthetic sense'.

Sas designed the very first products of BuzziSpace, which were made out of ecofelt, a hundred percent recycled material made of old plastic bottles. They were an instant hit and won several awards. BuzziSpace was catapulted into the spotlight and rapidly expanded its range keeping its original philosophy in mind: ecology, flexibility and acoustics.

BUZZISPACE PRODUCTS

| | | | | | | | | |
|---|--|--------------------------|---------------------------------------|--|---|--|--------------------------------|--|
| 2007 BuzziBoard BuzziScreen BuzziZone | 2008 BuzziBack BuzziLight | 2009 BuzziSkin | 2010 BuzziGrip BuzziTile | 2011 BuzziTwist BuzziSeat | 2013 BuzziBrickBack BuzziRug | 2014 BuzziCactus BuzziFalls | 2015 BuzziScreen Mix | 2016 BuzziSkin Printed BuzziLight Mono BuzziLight Alhambra BuzziLight Royal BuzziFalls Standing BuzziChandelier |
|---|--|--------------------------|---------------------------------------|--|---|--|--------------------------------|--|

Alain Gilles



Design is in the details.



After studying Political Sciences and Marketing Management, Alain Gilles went on to work in the international financial world for five years, but he decided to follow his passion. Thanks to the moral support of his wife, he went back to study Industrial Design in France. He opened his own studio in 2007 in order to pursue his dreams and develop his personal approach to product design, furniture design, art direction and scenography. In 2012, he was named "Designer of the Year" by the prestigious Interieur Kortrijk Foundation in Belgium.

Alain Gilles started designing for BuzziSpace in 2009 and developed the BuzziHood, an acoustic cocoon you can hang on the wall and a fun reminder of the classic vintage phone booths. Alain's experience with working in a corporate environment for 5 years also helped him understand the needs of open-plan offices, which he incorporated in new product ideas for BuzziSpace. Each of them are groundbreaking products that fit perfectly into the philosophy of BuzziSpace.

AWARDS

- 🏆 Henry Van de Velde Label 2011 (BuzziBooth)
- 🏆 Designer of the Year 2012
- 🏆 Interior Design HiP Awards 2014 (BuzziPicNic - Winner) • (BuzziVille - Honoree)
- 🏆 Contract Best of NeoCon 2014 (BuzziPicNic - Editors' Choice)
- 🏆 Interior Design Best of Year Award 2014 (BuzziVille - Best Furniture)
- 🏆 Interior Innovation Award 2014 (BuzziVille)
- 🏆 Architectural Products 2014 (BuzziVille - Product Innovation Award)
- 🏆 ADEX Silver Award for Design Excellence, 2014 (USA) (BuzziHive)
- 🏆 Good Design Award, 2014 (USA) (BuzziPicNic)
- 🏆 IMM Innovation Award 2014 (Cologne, DE) (BuzziPicNic)
- 🏆 Architizer A+ Award 2015 (BuzziPicNic - Jury Winner)
- 🏆 Interior Innovation Award 2015 (BuzziPicNic)
- 🏆 iF Design Award 2015 (BuzziPicNic)
- 🏆 Azure AZ Award 2015 (BuzziPicNic - Award of Merit)
- 🏆 Architectural Record Products of the Year 2015 (BuzziHub Open - Best in Category)
- 🏆 Interior Design HiP Award 2016 in category 'Accessories' (BuzziBlinds - Winner)
- 🏆 Interior Design Best of Year Award 2016 (BuzziFloat - Best Seating: Contract/Conference)
- 🏆 Wallpaper Design Award 2017 (BuzziBlinds)
- 🏆 Architect's Newspaper 2017 Best of Products Award in category 'Commercial Interior Furniture' (BuzziFloat)
- 🏆 Design Week Awards 2017 in category 'Furniture Design' (BuzziFloat - Honoree)
- 🏆 Contract Best of NeoCon 2017 in category 'Lighting' (BuzziHat - Silver Award Winner)
- 🏆 Hospitality Design Awards 2018 in category 'Lighting' (BuzziHat - Winner)
- 🏆 Interior Design HiP Awards 2018 in category 'Lighting' (BuzziHat - Winner)
- 🏆 Buildings' Product Innovations 2018 in category 'Seating' (BuzziSpark - Honoree)
- 🏆 Interior Design HiP Awards 2018 in category 'High Back Seating' (BuzziSpark - Honoree)
- 🏆 Buildings' Product Innovations 2018 in category 'Lighting' (BuzziZepp LED - Honoree)
- 🏆 Archiproducts Design Awards 2018 in category 'Office' (BuzziBracks - Winner)

BUZZISPACE PRODUCTS

| | | | | | | | | |
|--|--|---|--------------------------|--|---|----------------------------|--|---------------------------|
| 2010 BuzziHood BuzziBooth | 2011 BuzziBlinds Classic BuzziHub BuzziHub Table | 2012 BuzziGrid BuzziBooth Targa BuzziCockpit BuzziTemp | 2013 BuzziHive | 2014 BuzziVille BuzziMilk BuzziMilk Table BuzziPicNic BuzziDesk FlipFlop | 2016 BuzziBlinds BuzziPicNic Round BuzziFloat | 2017 BuzziMirage | 2018 BuzziHat BuzziSpark BuzziZepp BuzziZepp LED BuzziBracks | 2019 BuzziTable |
|--|--|---|--------------------------|--|---|----------------------------|--|---------------------------|

13&9 Design

“ We encourage interdisciplinarity in every design project. Our different backgrounds give us the flexibility to use unconventional skills in developing new products.

Austrian product design firm 13&9 was founded in 2013 in Graz and is based on the partnership between architect and CEO of INNOCAD Architecture, Martin Lesjak (Contract magazine’s Designer of the Year) and designer Anastasia Su (who also studied medicine). 13&9 is a design studio for international companies and also has its own label that designs, produces and sells their own products. The interdisciplinary team’s successful cooperation with specialist partners has led to achievements in furniture, lighting, floor coverings, fashion, accessories and art objects, as well as exhibition and sound design projects. 13&9 collaborated with BuzziSpace for the first time in 2016 and created the BuzziBalance and BuzziBalance Board. Two pieces that encourage movement and energy—creating a hub of social activity in the office space.



BUZZISPACE PRODUCTS

- 2016 BuzziBalance
- 2017 BuzziPleat
- 2018 BuzziPleat LED

AWARDS

- 🏆 Interior Design HiP Award 2016 in category ‘Well-being’ (BuzziBalance - Honoree)
- 🏆 Contract Best of NeoCon 2016 in category ‘Office Accessories’ (BuzziBalance - Gold Award Winner)
- 🏆 Good Design Award 2016 (BuzziBalance)
- 🏆 Active Office Award 2017 (BuzziBalance)
- 🏆 Architectural Record’s Record Products 2017 in category ‘Best Furnishings’ (BuzziPleat)
- 🏆 Buildings’ Product Innovations 2017 in category ‘Merit Award: Acoustics’ (BuzziPleat)
- 🏆 Contract Best of NeoCon 2017 in category ‘Acoustic Panels & Solutions’ (BuzziPleat - Gold Award Winner)
- 🏆 Interior Design Best of Year Award 2017 in category ‘Acoustic Furnishings’ (BuzziPleat)
- 🏆 Interior Design HiP Awards 2017 in category ‘Accessories’ (BuzziPleat)
- 🏆 Archiproducts Design Selection 2018 (BuzziPleat LED)
- 🏆 Hospitality Design Awards 2018 in category ‘Other’ (BuzziPleat LED - Winner)



Jeffrey Huyghe

With a background in industrial product design, mechanical engineering, and lighting, Belgian designer Jeffrey Huyghe has a broad understanding of different design disciplines. Architectural lighting was his first love and has only grown bigger throughout the years. This, however, hasn’t stopped the young talent from extending his portfolio to include other designs, for instance, acoustic solutions. Lighting or non-lighting, there’s a common theme, a signature, that unites Jeffrey’s portfolio. Everything rotates. Everything is built to move and to surprise!

BUZZISPACE PRODUCTS

- 2019 BuzziDish

“ Everything I create has a spark of magic. Each design holds a moment of surprise while maintaining its original purpose.

Jonas Van Put

Jonas Van Put is a young Belgian interior architect and furniture designer. He creates monumental steel constructions, furniture and art installations that question and improve social interaction. He is intrigued by nature, landscapes and everything that derives from this. The underlying processes of nature as well as artificial circumstances on different scales fascinate him. The launch of the BuzziJungle introduced the design world to young Belgian talent Jonas Van Put. It was Van Put’s first project with an international manufacturer.

BUZZISPACE PRODUCTS

- 2016 BuzziJungle



“ In every design, I pay attention to the relationship with its public, and question social interactions among people.

AWARDS

- 🏆 #MetropolisLikes Award 2016 (BuzziJungle)
- 🏆 Interior Design HiP Award 2016 in category ‘Office Furniture’ (BuzziJungle - Honoree)



Chris Hardy

Chris Hardy is an American industrial designer based in Atlanta. Born in 1984, he pursued an education in design, receiving a BFA from the College for Creative Studies in Detroit and a Masters of Design from the School of Design at the Hong Kong Polytechnic University. After returning to the United States in 2009, he began his career as a freelance designer collaborating with companies for both industrial and graphic design. His clients include interior design firms, retail stores, furniture and lighting manufacturers, and design publications. For the expansion of BuzziSpace’s range of acoustical lighting solutions, Chris Hardy created a distinctive new pendant shape, named BuzziBell, that won an Interior Design HiP Award Honoree at NeoCon 2016.

“ I aim to develop pieces that can be connected with on an emotional level. My work is inspired by the challenge of personalization in the modern world and the increasing desire we have to own objects that match our own styles and philosophies.



BUZZISPACE PRODUCTS

- 2016 BuzziBell



Gerd Couckhuyt

Belgian designer Gerd Couckhuyt opened his own design studio 'Bhoom' in 2012 and was a late bloomer in the design world. At a very young age, he began his career at Bekaert Engineering as a mechanic and later as an electrician. At the age of 18, his interest for interior design was stimulated by a friend who painted. Later he obtained several degrees in art, interior design, light consultancy and sculpture art. The combination of his technical background and his feeling for creation and art makes him a more complete designer with an eye for the visual and the technical aspects. His inspiration comes from daily visual and emotional impulses. Designing objects and interiors is not an assignment for Gerd, but a distillation and fine-tuning of ideas already present in his mind. He now works for several international brands, such as Modular, Wildspirit, Manutti, etc. With his design 'Elements' for Manutti he won the prestigious Red Dot Award in 2014.

“

All our furniture designs share a certain relationship: there is always a link, a kind of visual logic and a magical interplay of relationships. Call it unity in diversity if you will. Conspicuous details give all our designs a distinct identity and catch everyone's eye.

AWARDS

🏆 Interior Design HiP Awards 2017 in category 'Hospitality: Seating' (BuzziBounce - Honoree)

BUZZISPACE PRODUCTS

2016 BuzziBounce
BuzziPlank

Wiebe Boonstra & Marc van Nederpelt

“

You always remember the man with the scar.

DUM OFFICE is a Dutch design studio founded by designers Wiebe Boonstra and Marc van Nederpelt in the late nineties. The main objective of DUM OFFICE is to provide spaces with distinctive items all with a recognizable DUM signature: edgy, clean, playful, colorful and subtle. BuzziCane fits perfectly in their playful aesthetic signature and in our BuzziSpace DNA. The informal design of the BuzziCane welcomes guests with its friendly feel.



AWARDS

🏆 #MetropolisLikes Best of NeoCon 2017 (BuzziCane)

🏆 Architectural Record's Record Products 2017 in category 'Best Lighting Products' (BuzziCane)

BUZZISPACE PRODUCTS

2016 BuzziCane

Cory Grosser

“

As a designer, empathy is crucial. It's about understanding and transforming how people feel in a space. Of course, functionality is important too, but nothing beats putting a smile on people's faces.

Cory Grosser + Associates ("CG+A") is a multi-disciplinary, boutique design agency that implements beautiful design for the benefit of commerce and culture. Founded in 2002 by American designer, Cory Grosser, CG+A's approach drives creative strategies for brands and engaging narratives for people. The Pasadena-based studio has collaborated with many top American and international brands on projects in the fields of: architectural design, furniture and product design, design strategy and creative direction.



AWARDS

🏆 Interior Design HiP Awards 2018 in category 'Biophilic Acoustics' (BuzziMood - Winner)

BUZZISPACE PRODUCTS

2018 BuzziMood

“

Our biggest challenge is to constantly innovate and search for an innovative and original approach which we can be proud of.

COUVREUR.DEVOS

Bram Couvreur & Björn De Vos are a Belgian design duo who dare to reach beyond the borders of the everyday. COUVREUR.DEVOS is part of Maister, a creative agency, and focuses on interior design and product development. Whether it's a question of lighting, champagne bottles or designing an interior: they make sure form and function are in harmony every single time. In 2012, they designed BuzziWings for BuzziSpace, an inventive partition that ensures optimum acoustics and a subtle lighting of the room thanks to the integrated, indirect light source.



BUZZISPACE PRODUCTS

2012 BuzziWings

Axel Enthoven

Axel Enthoven (1947) a big name in design land. With his design bureau, Yellow Window (formerly known as Enthoven Associates Design Consultants), he not only designs furniture but also buses, trams, trains or even medical equipment. This Antwerp-based design bureau has already made 1,900 products, and is active worldwide in product development, design consultancy and innovation research. The team has won several awards, including various Red Dot Design Awards and IF Design Awards. For his pioneering work in the design sector, Axel Enthoven received the Henry Van de Velde Award in 2004. For BuzziSpace he designed the BuzziMe in 2012. The ideal lounge chair to get away from it all.



“

The big difference between designing today and in the past is that designing now has become teamwork, while it used to be a one-man business. Today there are so many different elements associated with our profession that are very important like for example marketing.

BUZZISPACE PRODUCTS

2012

BuzziMe

2018

BuzziMe Low



Stal Collectief

Stal Collectief is a collaboration between four young furniture designers who studied in Mechelen (Belgium): Len de Paepe, Bob Segers, Tim Vranken and Jonas Blondeel. This collective, which occurred through common interest and friendship, wants to create timeless and honest pieces of furniture and lighting objects. New ideas are conceived, prototyped and sometimes even developed under one roof. The BuzziShade, which provides light and absorbs sound at the same time, is the culmination of an artistic collaboration between BuzziSpace and the four young Belgian furniture designers of Stal Collectief.

BUZZISPACE PRODUCTS

2013

BuzziShade



Jean-Pierre Galeyn

“

We design from the bottom up, creating unique, innovative products appreciated by consumers, concerned by better quality and long-term use.

Jean Pierre Galeyn owns a craft workshop called Tradewinds, where outdoor and garden products are created, assembled and distributed. The art of outdoor living is their main concern, so they reshape widely used and distributed products to restore their authentic purpose and make them lasting, user-friendly and pleasant to the eye. They seek for the perfect blend between authentic craftsmanship and new technology to achieve unique objects.

BUZZISPACE PRODUCTS

2015

BuzziShed

Anthony Duffeleer

“

Designing is the outcome of a process where the role of the designer is seriously relative. The material, the production process and other parameters control the direction and form of our designs.

The Flemish architect Anthony Duffeleer heads the Antwerp-based agency Frap together with architect Freia Rombouts. The duo is specialized in product design and architecture. In addition to this, Duffeleer is the initiator of Xala, a collection of must-haves for house and garden. As a designer he is particularly interested in the quest for the right production method. In 2010, he designed a funky room divider for BuzziSpace, named BuzziPlant.

BUZZISPACE PRODUCTS

2010

BuzziPlant

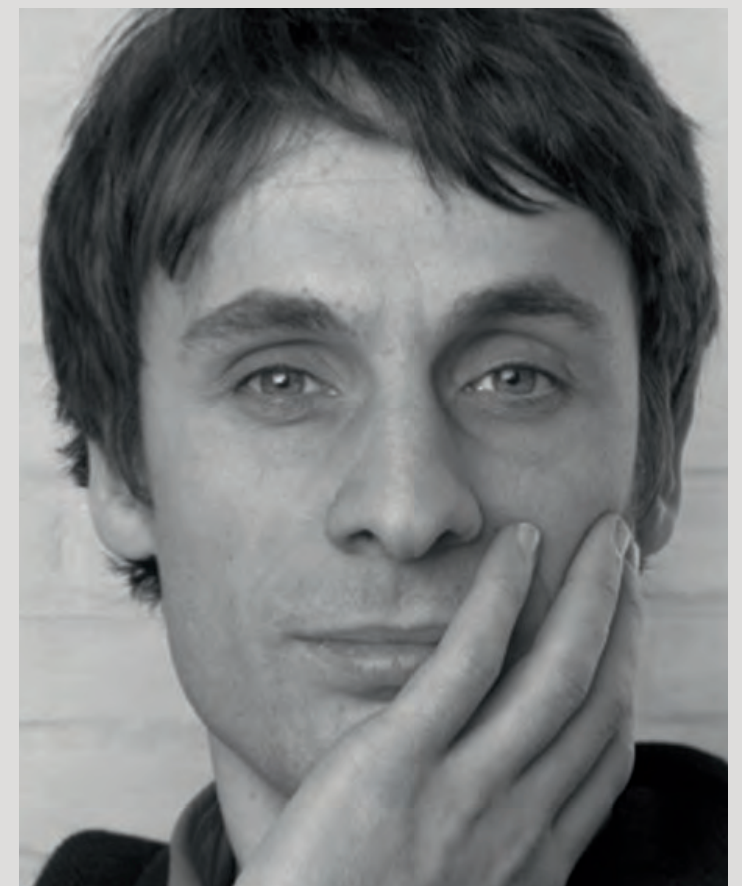

Silence is Not a Luxury

From the very beginning, acoustics have been a driving force when developing or considering new products. A well-balanced room with a perfect acoustical level is a key factor to the performance and well-being of workers all over the world and therefore our logical main concern. For BuzziSpace, acoustics is more than just a generic word. It's our way of caring for workers and contributing to a pleasant working environment by balancing any given space with the recommended reverberation time and enhancing the speech intelligibility.



WHAT IS SOUND

FREQUENCY
DECIBEL
REVERBERATION TIME

Sound consists of pressure waves that run through the air. It can be described as energy, created by vibrations, transmitted through air or any other medium. The inner ear transfers those vibrations into sound. These sound waves have 2 different characteristics: frequency and decibel. **Frequency** determines the tone of the sound, while **Decibel** determines the intensity of sound.

Frequency

The wavelength determines the sound frequency. It is measured as the number of repetitive vibrations per cycle per second and is expressed in Hertz. The audible range of sound is between 20 to 20 000 Hz. The higher the frequency, the higher the tone.

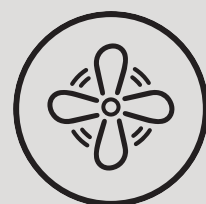
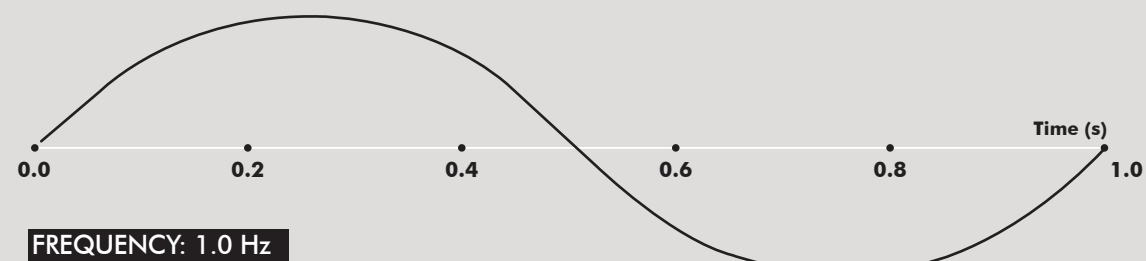

Low tone

Long wave - Low frequency (50 - 250 Hz)
E.G. heating systems, ventilation, elevators, copy machines, server rooms

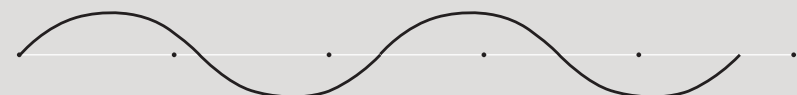

Mid tone

Mid length wave - Speech frequency (250 - 2500 Hz)
E.G. speech, vowels, consonants

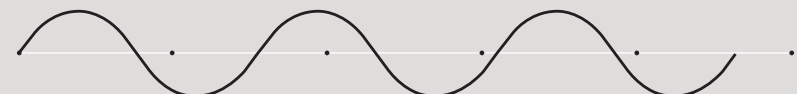

High tone

Short wave - High frequency (2500 - 12000 Hz)
E.G. ringtones, typing sounds, clicking sounds, kids

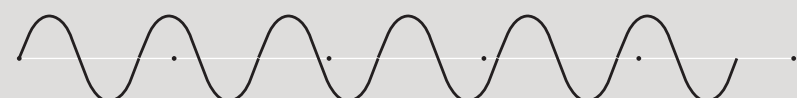

WHAT IS SOUND

FREQUENCY
DECIBEL
REVERBERATION TIME

Decibel

Decibel is a logarithmic unit to express the ratio of sound intensity (volume) and is important as an indicator of the background noise level. Humans can hear sounds between 0 and 140 decibels.

The value of decibels has no direct or indirect correlation with the sound frequency. For example, the ticking of a clock and the buzzing of a vacuum cleaner may have the same frequency but a different volume.

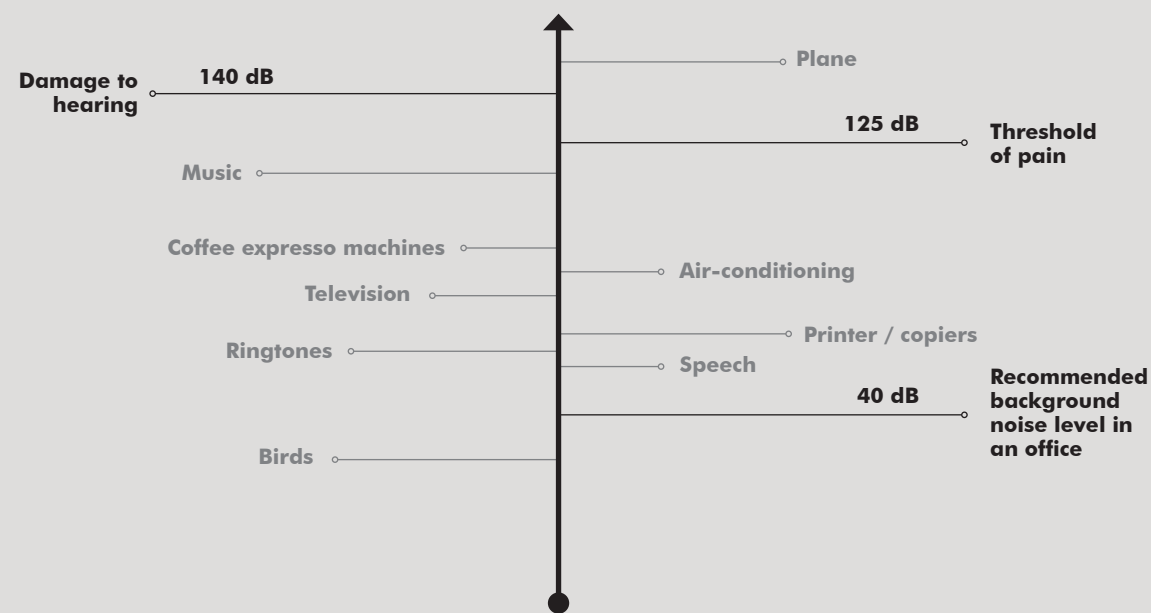

Reverberation time

Reverberation time is the time needed for an original sound source to decay 60 dB and is expressed in seconds. In order to generate excellent speech intelligibility and clarity, the reverberation time should be adjusted and balanced by means of absorptive material in function of the specific acoustical issues in a given space. The recommended reverberation time will always have to be adapted to the room volume and the type of activity.

RECOMMENDED REVERBERATION TIME:

- > Office: 0.75s
- > Meeting room: 0.60s
- > Cafeteria: 1.00s
- > Gymnasium: 1.50s
- > Auditorium: 1.50s to 2.00s

INFLUENCES ON THE Reverberation time

- 📏 VOLUME OF THE ROOM
- 🌡️ ROOM TEMPERATURE
- 👉 ABSORPTION COEFFICIENT OF MATERIALS, OBJECTS AND PEOPLE IN A ROOM

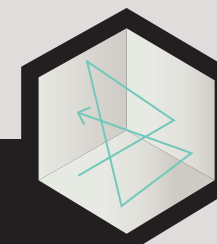

BUZZISPACE ACOUSTICS

CONTINUOUS TESTING
HOW TO READ ACOUSTIC REPORTS
ACOUSTIC AMBASSADOR
ACOUSTIC PRINCIPLES
BUZZISPACE RT60

Continuous testing

All acoustic products are tested to determine the absorption performance following the reverberation room method. All tests are done in an accredited test laboratory, Peutz bv.



How to read acoustic reports

This chart shows the equivalent absorption area (A_{eq}) of 4 different variations of our BuzziClipse with their metric Sabin value in all the relevant frequencies, where one square meter equals one metric Sabin.

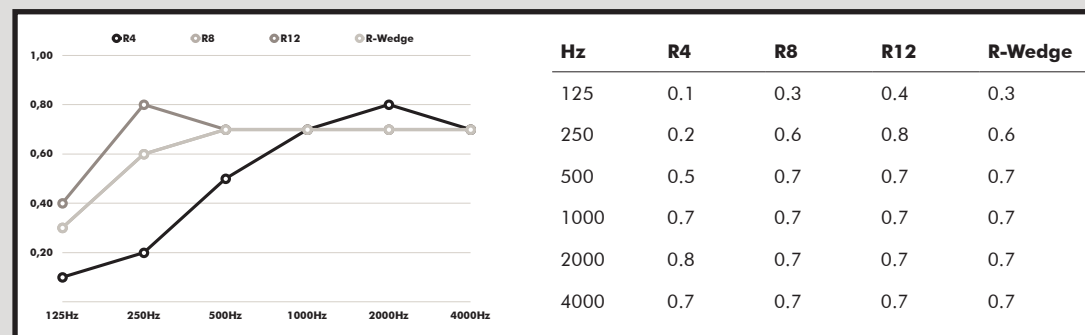
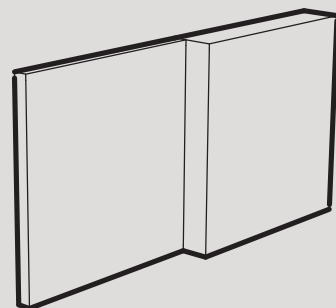

EQUIVALENT SOUND ABSORPTION AREA (AEQ) EXPRESSED IN SQUARE METER

- > A Sabin is the unit for the absorption of sound, equal to the absorption provided by 1 square meter (foot) of a completely absorbing product.
- > This is the only accepted and certified method, applied to freestanding products.
- > Depending on the position in the room, the product will react in a different way but will always generate the same amount of equivalent absorption area.

All acoustic reports can be found on our website: www.buzzi.space

Acoustic Ambassador

DANIEL VERLOOVEN

He travels the globe sharing his expertise and knowledge through seminars, trainings and lectures for an audience of A&D and facility managers.

As an expert, he supports the product development team with advice and recommendations on how to get the best performance out

of new acoustical products. His role includes monitoring acoustic testing and calculating the performance rates of the BuzziSpace acoustical portfolio. Daniel also provides training, support and consultancy for the global BuzziSpace sales network and community.

He also writes and develops CEU and CPD programs helping professionals gain knowledge about the importance of acoustics.



BUZZISPACE ACOUSTICS

CONTINUOUS TESTING
HOW TO READ ACOUSTIC REPORTS
ACOUSTIC AMBASSADOR
ACOUSTIC PRINCIPLES
BUZZISPACE RT60

Acoustic Principles

To create a better acoustical environment and reduce reverberation time in a room, BuzziSpace products are developed to perform on one or more of the following acoustic principles.

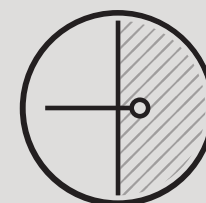

Absorption

Sound waves are absorbed by any 'acoustically soft' material they encounter.

Sound is energy and in order to stop this energy from propagating, absorptive panels will be used to convert this energy into heat through friction. The absorption coefficient of a product will determine the level and quality of absorption. Absorption applies to fixed wall or ceiling elements.

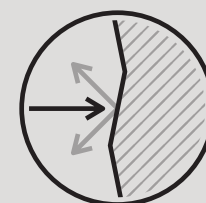

Diffusion

Sound energy is spread evenly in a given space.

Wavelengths which cannot be absorbed through acoustic treatment will scatter evenly back into the room, ensuring a better spread while maintaining a live, vivid sound. This property can be obtained by alternating different depths of absorptive material and 3D shapes.

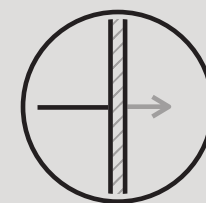

Attenuation

Reducing the sound transfer within a room.

In order to reduce the sound transfer between different spaces, vertical elements will be applied to cut down sound energy. Those can come in different shapes such as sound blocks, vertical ceiling panels, room dividers, desk screens. Attenuation or sound dampening has a positive impact on speech intelligibility and clarity.

BuzziSpace RT60

A MUSTHAVE FOR ACOUSTIC GEEKS



When decorating a space, we often think of only the most visible items: tables, chairs and curtains. But what we do not see —the acoustics of the room— is too often forgotten. The RT60 app, developed by BuzziSpace, measures the reverberation time in each room and suggests products to improve sound quality. With the simulation tool, you can see the acoustical impact of BuzziSpace products in your room.

MORE INFO ON HOW TO GET STARTED ON BUZZI.SPACE/NOISE-REDUCTION



For detailed acoustic reports check the product page on our website: www.buzzi.space

BuzziBlinds Classic

— By Alain Gilles

Room divider

These rotating acoustical blinds take their inspiration from modernist architecture—more specifically from the exterior sunshades that can be found on modernist buildings designed by Oscar Niemeyer. The free-standing room divider is made up of a series of five rotating acoustic blinds. With a simple twist, the blinds can be opened or closed to varying degrees to create privacy or open-up space. This gives individuals the opportunity to determine the level of privacy they may want or need at any given moment to concentrate on a specific task.



Volkswagen Financial IT offices - Berlin
Photography: Andrea Janssen

Dimensions

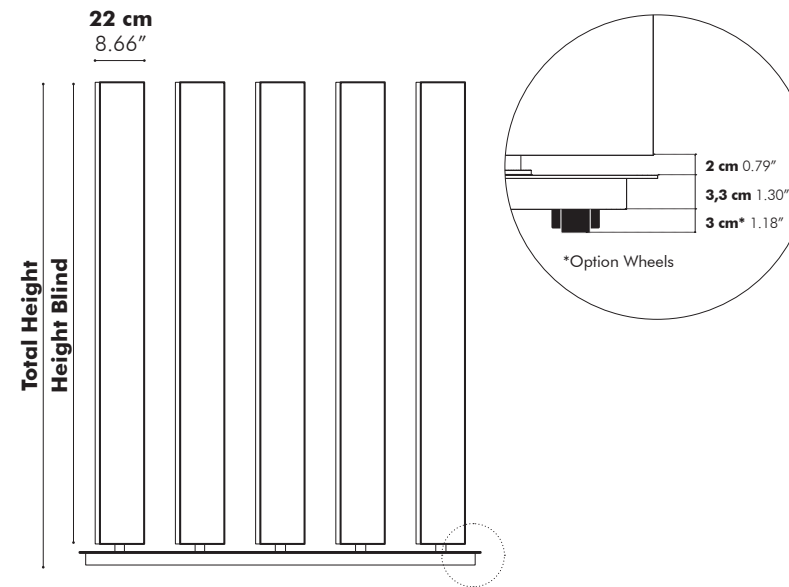

| | Height Blind | Total Height |
|----------|---------------|-----------------|
| S | 115 cm 45.28" | 120,3 cm 47.36" |
| M | 150 cm 59.06" | 155,3 cm 61.14" |
| L | 185 cm 72.83" | 190,3 cm 74.92" |

Baseplates

Curved 45°

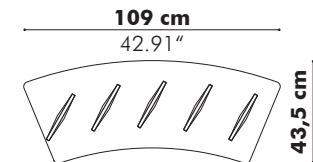

Regular

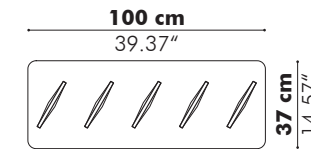

Finishes

Cover in BuzziFelt
Extra layer in fabric collections CAT A, B, C, D, E, F possible (check our application overview p. 312)
Baseplate in black (RAL 9005) or white (RAL 9010)

Options

Bicolor
Wheels (height + 3 cm | 1.18")

Acoustics

Acoustic Principles

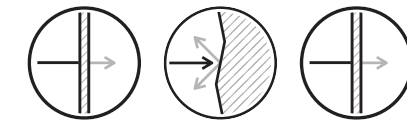

Attenuation Diffusion Attenuation

Acoustic Performance



Mid Tones High Tones

How to order

Size
Model & color Baseplate
Fabric (CAT > collection > color)
Option

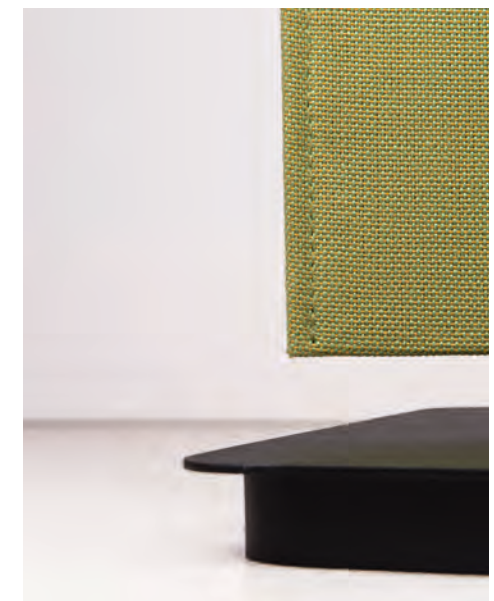
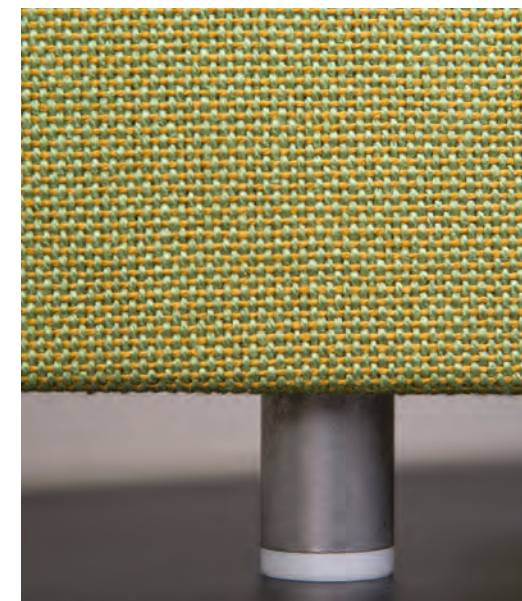

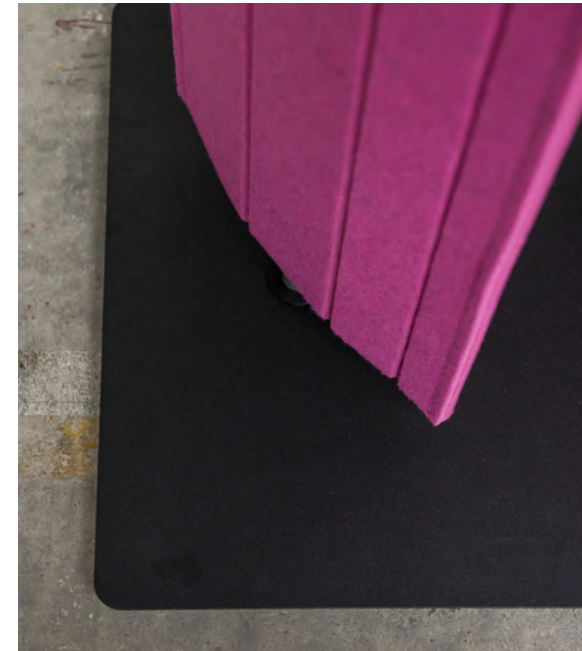

BuzziBlinds

— By Alain Gilles

Acoustical performance and privacy with a twist

New additions to the BuzziBlinds Classic. The new generation of BuzziBlinds offers 4 different shapes of the fins covered with plain BuzziFelt. The innovative v-cut technique strengthens the architectural and minimal look. The rhythm and tonalities created by the orientation of the v-cut add a dynamic of depth to any space.

Dimensions

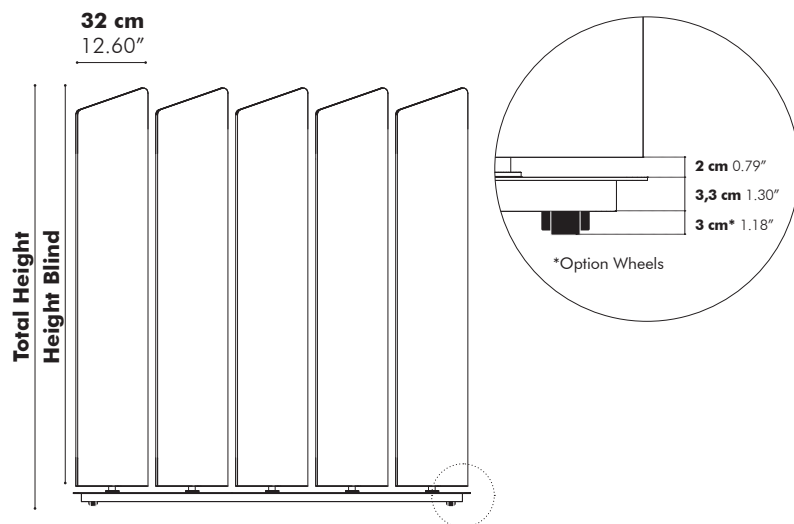

| | Height Blind | Total Height |
|----------|---------------|-----------------|
| M | 150 cm 59.06" | 155,3 cm 61.14" |
| L | 185 cm 72.83" | 190,3 cm 74.92" |

Baseplate

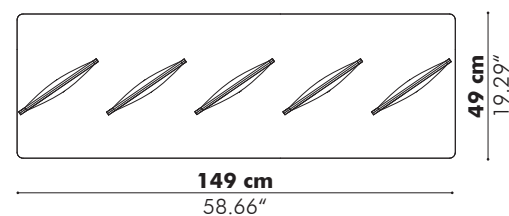

Models & Patterns

Blinds

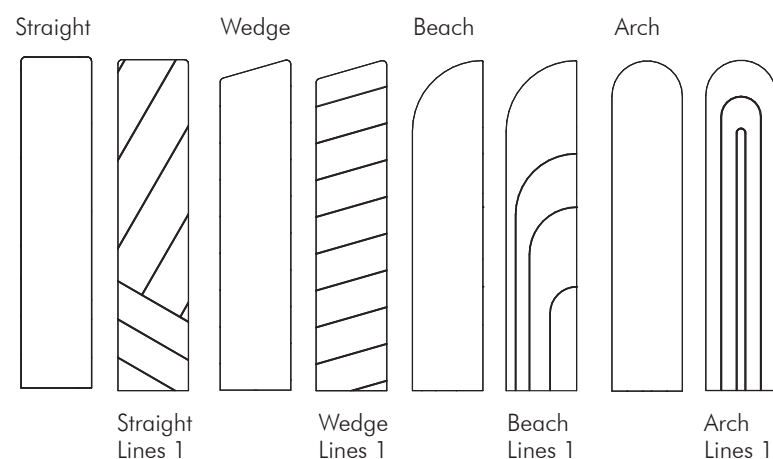

Finishes

Cover in BuzziFelt
Extra layer in fabric collections CAT A, B, C, D, E, F possible for Blinds without v-cut lines. (check our application overview p. 312)
Baseplate in black (RAL 9005) or white (RAL 9010)

Options

Bicolor
Wheels

Acoustics

Acoustic Principles

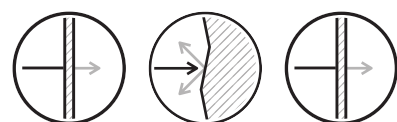

Attenuation Diffusion Attenuation

Acoustic Performance



Mid Tones High Tones

How to order

Model & Pattern
Size
Color baseplate
Fabric (CAT > collection > color)
Option



